



WORLD-BEAM® QS30EDV

Expert™ Diffuse-Mode Sensor with a Visible Red Beam



Contact Factory for more information.

Features

- Easy-to-set automatic *Expert*-style Static and Dynamic TEACH options, multiple Single-Point SET options, plus manual adjustment for fine tuning
- Smart power-control algorithm to maximize performance in low-contrast applications
- Normal mode provides 1.8 ms sensing response with improved crosstalk avoidance routine (for two sensors) and improved fluorescent light immunity
- Selectable high-speed (HS) mode option for 300-microsecond response (crosstalk avoidance and fluorescent light immunity disabled)
- Easy push-button Dark Operate/Light Operate select, output OFF-delay, and operating speed setup
- Powerful, highly collimated visible red sensing beam
- Tough ABS housing is rated IEC IP67; NEMA 6
- Easy-to-read operating status indicators, with 8-segment bargraph display
- Bipolar discrete outputs, PNP and NPN
- Selectable 30-millisecond OFF-delay
- Models available with 2 m or 9 m (6.5' or 30') cable or integral quick-disconnect
- Compact housing, mounting versatility – via popular 30 mm threaded barrel or side-mount

Models

Model	Range	Cable*	Supply Voltage	Output Type
QS30EDV	High-Speed Mode: 1,100 mm (43") Normal Mode: 1,400 mm (55")	2 m (6.5') 5-wire cable	10 to 30V dc	Bipolar NPN/PNP
QS30EDVQ		Integral 5-pin Euro-style QD		

* 9 m cables are available by adding suffix "W/30" to the model number of any cabled sensor (e.g., QS30EDV W/30).
A model with a QD connector requires a mating cable; see page 10.



WARNING . . . Not To Be Used for Personnel Protection

Never use these products as sensing devices for personnel protection. Doing so could lead to serious injury or death.

These sensors do NOT include the self-checking redundant circuitry necessary to allow their use in personnel safety applications. A sensor failure or malfunction can cause either an energized or de-energized sensor output condition. Consult your current Banner Safety Products catalog for safety products which meet OSHA, ANSI and IEC standards for personnel protection.

WORLD-BEAM® QS30EDV

Overview

The QS30EDV is an easy-to-use diffuse-mode sensor. It provides high-performance sensing in low-contrast applications. Its visible red beam provides easy sensor alignment. The sensor offers multiple configuration options, in addition to manual fine adjustment, remote programming, and security lockout options.

The sensor features bipolar outputs, one each NPN and PNP.

The sensor's compact housing has a large, easy-to-see bargraph display plus bright LEDs for easy configuration and status monitoring during operation. LEDs # 1–4 of the bargraph display also show configuration status during SETUP. The sensor can be side-mounted, using its integral mounting holes, or front-mounted, via its 30 mm threaded barrel.

Sensor Configuration

Sensor configuration is accomplished through TEACH or SET options, plus SETUP mode. After TEACH or SET have defined the sensing parameters, SETUP mode may be used to enable the delay, to change the Light Operate/Dark Operate status, or to select the high-speed response option (HS). Manual Adjust may be used to fine-tune the thresholds (see page 7). Two push buttons, Dynamic (+) and Static (-), or the remote wire, may be used to access and set the parameters.

Sensor configuration options include:

- Dynamic (on-the-fly) TEACH: a single switching threshold, determined by multiple sampled conditions
- Two-Point Static TEACH: a single switching threshold, determined by two taught conditions
- Window SET: a sensing window, centered on a single sensing condition
- Light SET and Dark SET: a single switching threshold, offset from a single sensing condition

Remote Configuration

The remote function may be used to configure the sensor remotely or to disable the push buttons for security. Connect the gray wire of the sensor to ground (0V dc), with a remote programming switch connected between them. Pulse the remote line according to the diagrams in the configuration procedures. The length of the individual programming pulses is equal to the value T:

$$0.04 \text{ seconds} \leq T \leq 0.8 \text{ seconds}$$

Returning to RUN Mode

Configuration modes each may be exited either after the 60-second time-out, or by exiting the process:

- In static TEACH or SET modes, press and hold the Static (-) button (or hold the remote line) for 2 seconds. The sensor returns to RUN mode without saving any new settings.
- In SETUP mode, press and hold both the Static (-) and Dynamic (+) buttons (or hold the remote line) for 2 seconds. The sensor returns to RUN mode and saves the current setting.

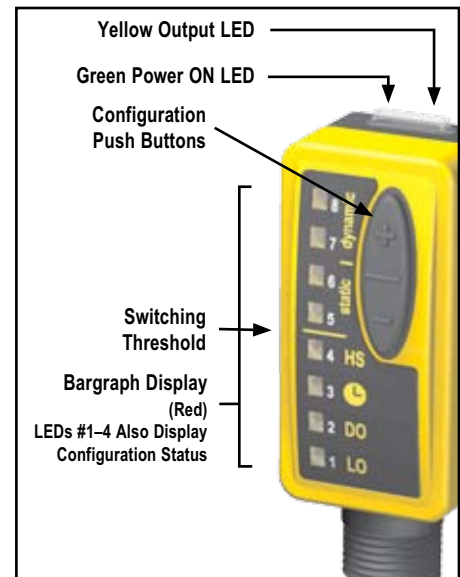



Figure 1. Features

WORLD-BEAM® QS30EDV

Specifications

Sensing Beam	660 nm visible red
Supply Voltage	10 to 30V dc (10% max. ripple) @ 25 mA max current, exclusive of load
Supply Protection Circuitry	Protected against reverse polarity, over voltage, and transient voltages
Delay at Power-Up	250 ms; outputs do not conduct during this time
Output Configuration	Bipolar: 1 current sourcing (PNP) and 1 current sinking (NPN)
Output Ratings	150 mA maximum load (derate ~ 1 mA/°C above 25°C) OFF-state leakage current: < 50 µA at 30V dc ON-state saturation voltage: NPN: < 200 mV @ 10 mA; < 1V @ 150 mA PNP: < 1.25V @ 10 mA; < 2V @ 150 mA
Output Protection	Protected against output short-circuit, continuous overload, transient over-voltages, and false pulse on power up
Output Response Time	High-Speed Mode: 300 microseconds Normal Mode: 1.8 ms
Repeatability	High-Speed Mode: 100 microseconds Normal Mode: 150 microseconds
Adjustments	2 push buttons and remote wire <ul style="list-style-type: none"> • Easy push-button configuration • Manually adjust (+/-) cutoff (push buttons only) • Light Operate/Dark Operate and OFF-delay configuration options (push buttons only) • Push-button lockout (from remote wire only)
Indicators	8-segment red bargraph: Distance relative to cutoff point Green LED: Power ON Yellow LED: Output conducting
Construction	ABS plastic housing; acrylic lens cover
Environmental Rating	IP67, NEMA 6
Connections	5-conductor 2 m (6.5') PVC cable, 9 m (30') PVC cable, or 5-pin integral Euro-style quick-disconnect fitting
Operating Conditions	Temperature: -10° to +55°C (+14° to 122°F), Max. relative humidity: 90% @ 55°C (non-condensing)
Vibration and Mechanical Shock	All models meet Mil. Std. 202F requirements. Method 201A (Vibration: 10 to 60 Hz max. double amplitude 0.06", maximum acceleration 10G). Also meets IEC 947-5-2 requirements: 30G, 11 ms duration, half sine wave.
Certifications	

Performance Curves

Performance based on use of 90% reflectance white test card

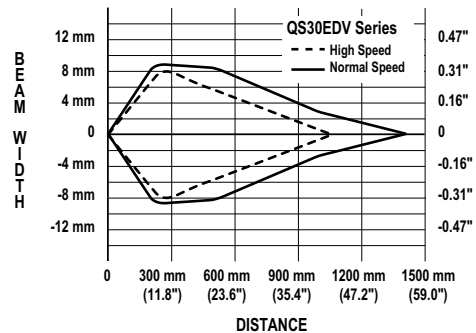
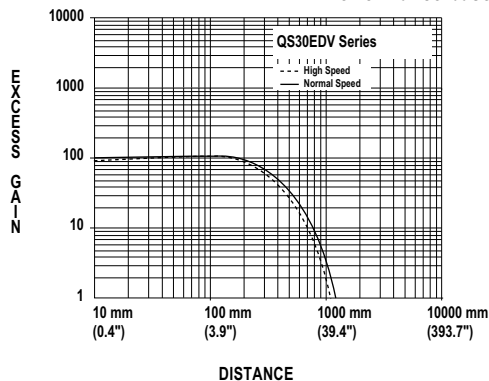

Dimensions

Cabled Models

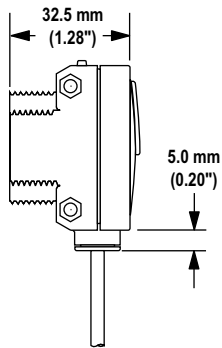

Hardware Included:

(10) M3 x 0.5 x 28 stainless steel machine screws, nuts and washers

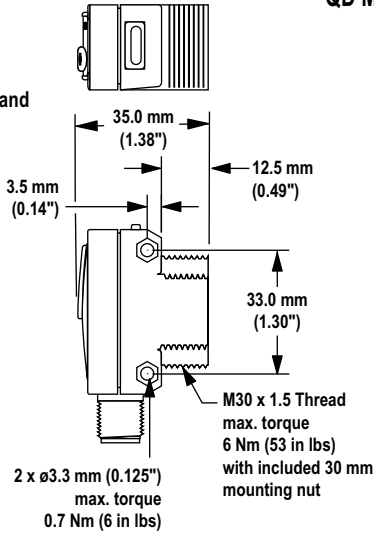
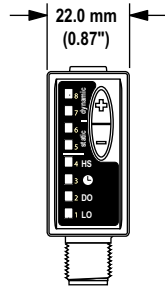

QD Models

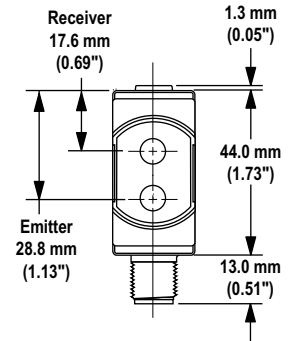

Hookups

Cabled Models

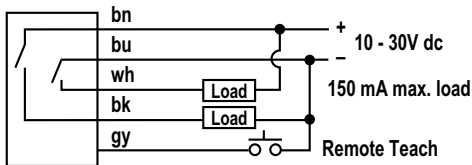

QD Models

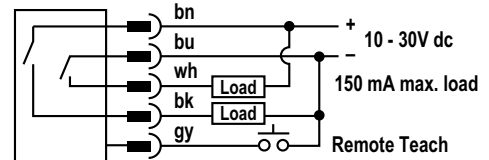

Accessories

Quick-Disconnect Cables

Style	Model	Length	Dimensions	Pinout
5-pin Euro-style straight	MQDC1-506 MQDC1-515 MQDC1-530	2 m (6.5') 5 m (15') 9 m (30')		
5-pin Euro-style right-angle	MQDC1-506RA MQDC1-515RA MQDC1-530RA	2 m (6.5') 5 m (15') 9 m (30')		